

RADIAL TYPES

TYPE	CODE NO (Terminal box type)
KYSA-B1 (SINGLE CONTACT)	550
KYSA-B2 (DOUBLE CONTACT)	560

TYPE	CODE NO
KYS-B0 (WITHOUT CONTACT)	541-1

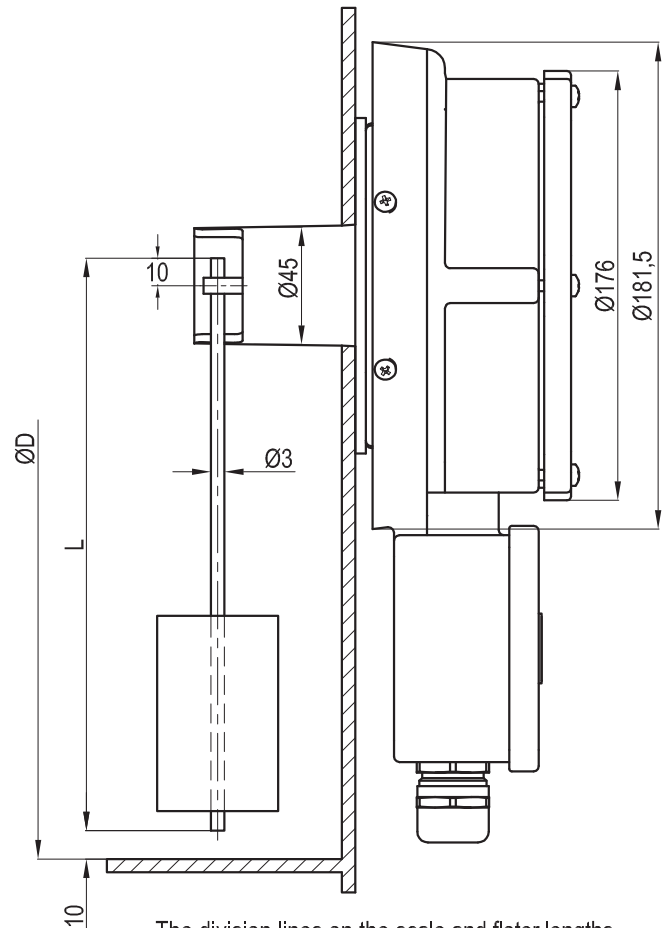
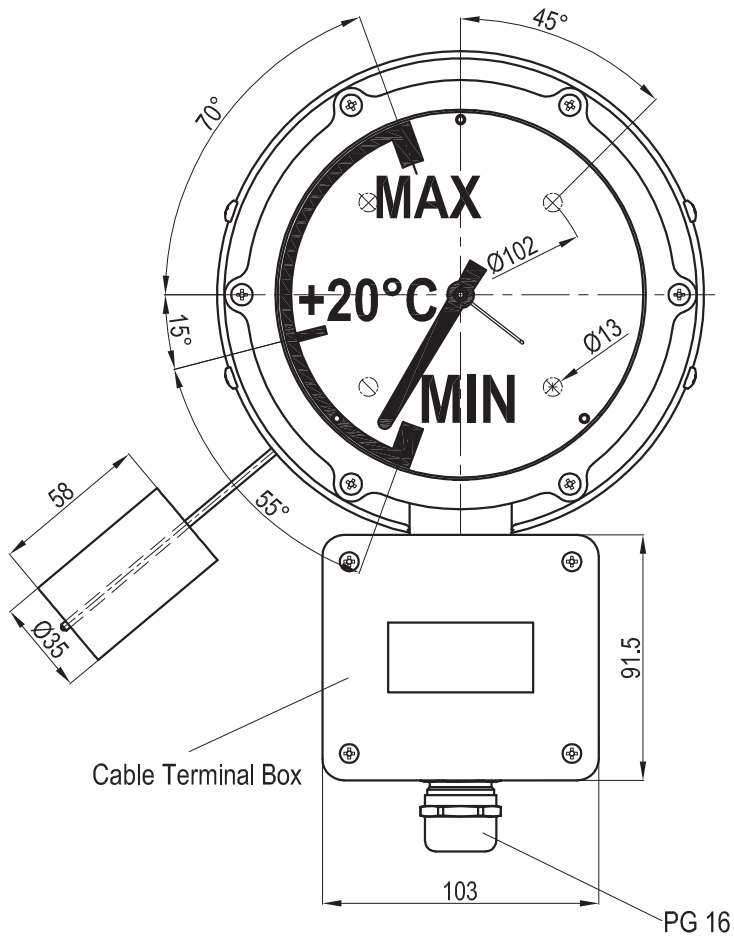

The division lines on the scale and floter lengths can be adjusted according to the oil level

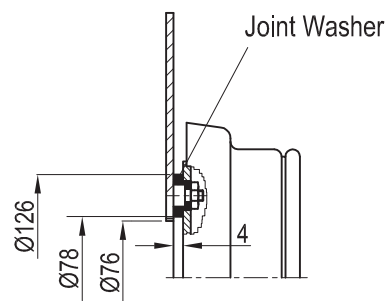
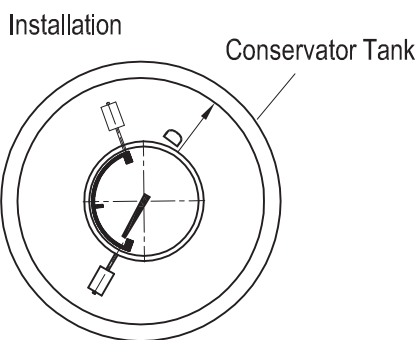

Installation measure acc. with DIN 42569

FLOAT LEVER LENGTH (L)	240	305	390	490	615	790
CONSERVATOR TANK DIAMETER (D)	500	630	800	1000	1250	1600

TERMINAL BOX TYPE CONNECTION

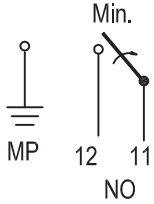
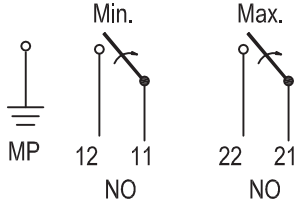
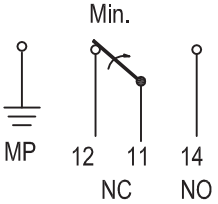
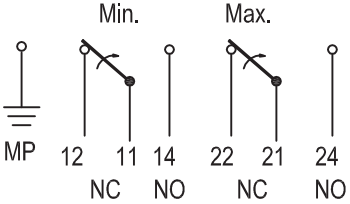
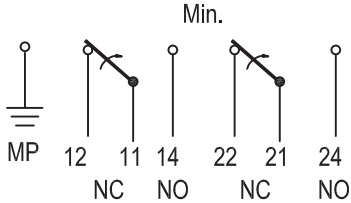
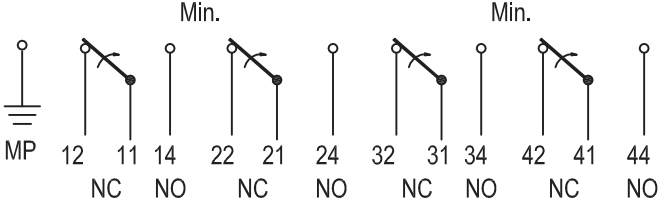
 <p>At minimum position, single contact standart connection</p>	 <p>Double contact, standard connection</p>
 <p>At minimum position, single contact changeover connection</p>	 <p>Double contact, changeover connection</p>
 <p>2 contacts for minimum level</p>	 <p>2 contacts for min.level (changeover) + 2 contacts for max.level</p>