

TYPE / FORM	CODE NO
MH 0,5 kg FORMC R 1/2"	611C
MH 0,5 kg FORMC R 3/4"	6311C
MH 0,5 kg FORMC R 1"	6111C

TYPE / FORM	CODE NO
MH 1.0 kg FORMC R 1/2"	621C
MH 1.0 kg FORMC R 3/4"	6211C
MH 1.0 kg FORMC R 1"	62111C

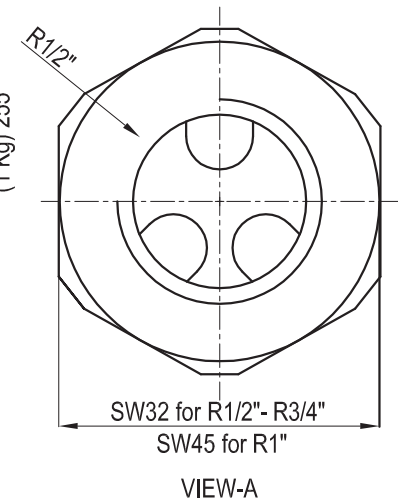

ITEM NO	QUANTITY		DESCRIPTION	SPECIFICATION
	0.5 KG	1 KG		
1	1	1	TOP SECTION	1 DIN 42567
2	1	1	BOTTOM SECTION	3 DIN 42 567
3	1	1	OIL BOWL	92X6X66 -3 DIN 42 567
4	1	1	HOLDER	5 DIN 42 567
5	1	1	SIEVE	45X1X6 - 5 DIN 42 567
6	1	-	GLASS CYLINDER	120X5X100-6 DIN 42 567
	-	1	GLASS CYLINDER	120X5X180-6 DIN 42 567
7	1	-	BRIDGING PLUG	12X125-7 DIN 42 567
	-	1	BRIDGING PLUG	12X205-7 DIN 42 567
8	2	2	GASKET	124X4X106 - 8 DIN 42567
9	1	1	GASKET	29X39X3 NBR
10	1	1	PLUG	R1" DIN 910
11	1	1	NUT	M12 DIN 934-4D
12	1	1	SPRING WASHER	B12 DIN 127
13	2	2	RIVET	2,3x5 DIN 1476
14	1	1	PIN	4x24 DIN 1471